

THIS DRAWING IS UNPUBLISHED. RELEASED FOR PUBLICATION 20  
 © COPYRIGHT 20 BY - ALL RIGHTS RESERVED.

**creo**  
 Creo Parametric 2.0  
**DO NOT REVISE EXCEPT BY CAD**

REVISIONS					
P	LTR	DESCRIPTION	DATE	DWN	APVD
K		ADDED SPEC ECO15-009694	29JUN2015	NCL	DAO

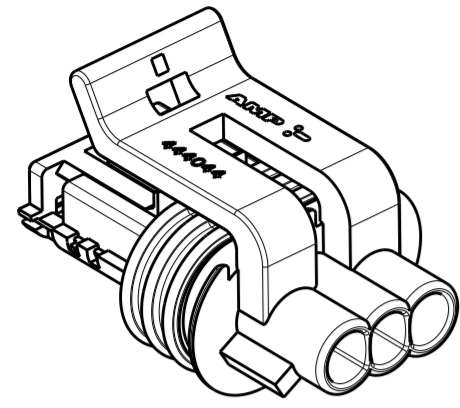

PERSPECTIVE VIEWS  
 SCALE 2:1

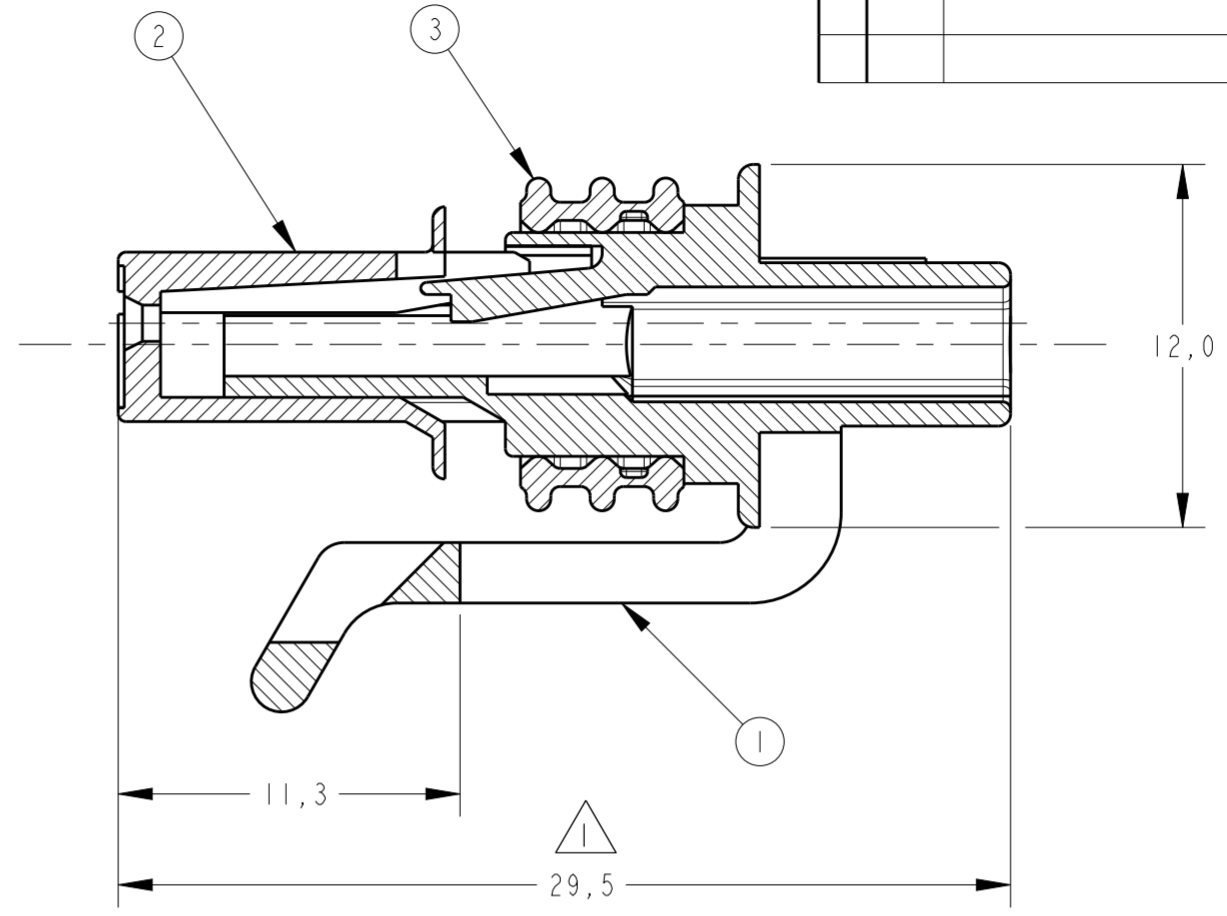
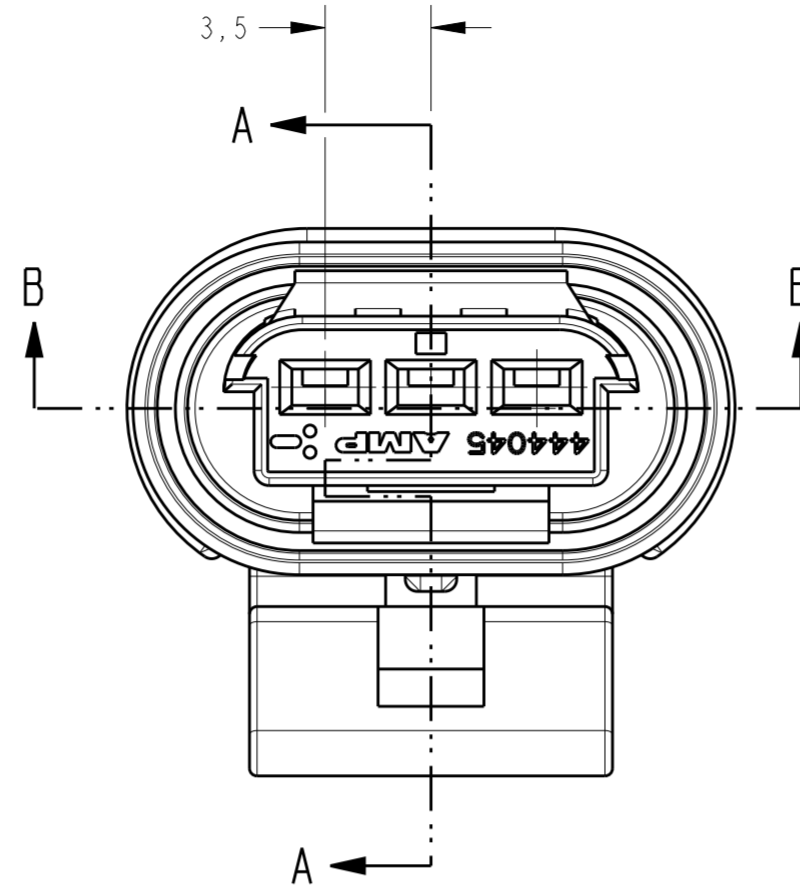
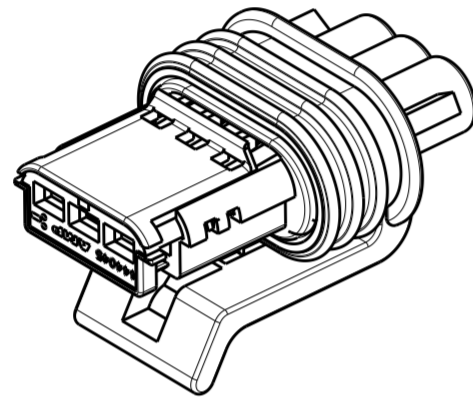

SECTION A-A

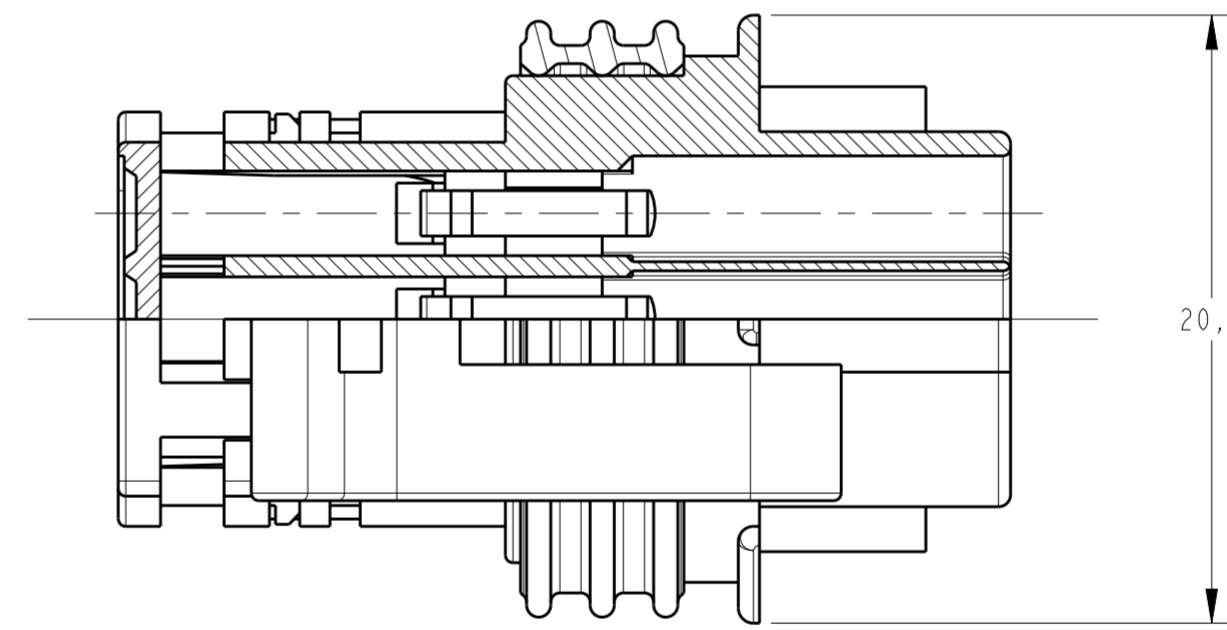

SECTION B-B

GRAVAÇÕES MARKINGS
LOGOTIPO AMP AMP LOGO
CÓDIGO PAÍS PRODUTOR MANUFACTURER COUNTRY CODE
NÚMERO COMPONENTE TE TE COMPONENT NUMBER
NÚMERO CAVIDADE CAVITY NUMBER
IDENTIFICAÇÃO CIRCUITO CIRCUIT IDENTIFICATION

△ - DEVE SER FORNECIDO NA CONDIÇÃO DE PRÉ TRAVAMENTO, CONFORME MOSTRADO.  
 2 - ESPECIFICAÇÃO PRODUTO: 108-37021

△ - MUST BE SUPPLIED IN PRE LOCK POSITION AS SHOWN.  
 2 - PRODUCT SPEC. 108-37021

REQ. PER ASSY	ITEM	DESCRIPTION	MATERIAL	NOTES
-	-	3 CONNECTOR SEAL.	SILICONE	VERDE / GREEN
-	-	2 SPACER, 3 POSN., MULTI-LOCK RECEP.	PA 6.6	AMARELO / YELLOW
-	-	1 HOUSING, 3 POSN., MULTI-LOCK RECEP.	PA 6.6	PRETO / BLACK

**INFORMAÇÕES DA CONTRA PEÇA**  
**MATING CONNECTOR INFORMATIONS**  
 SCALE 2:1

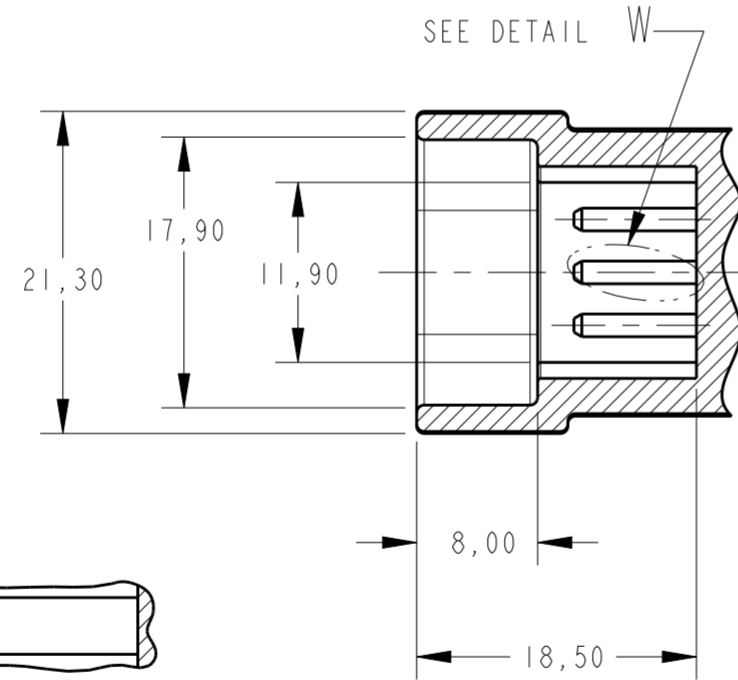
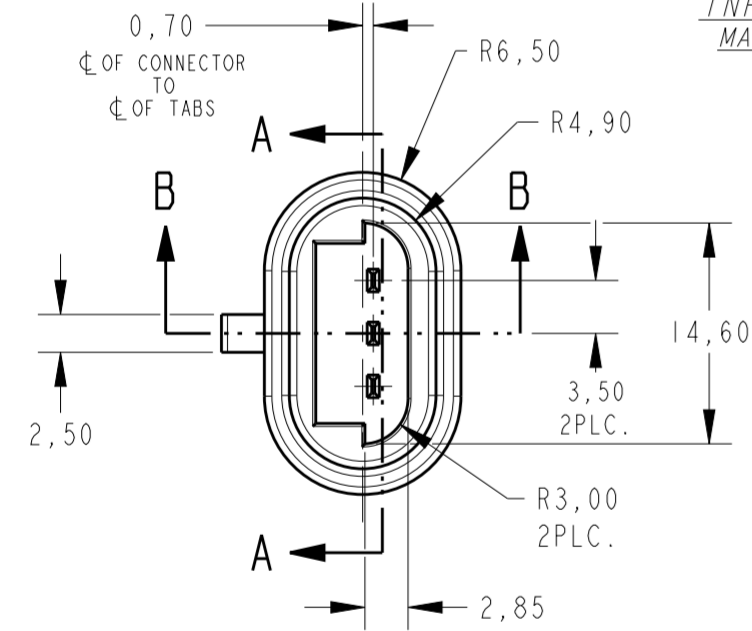

SECTION A-A

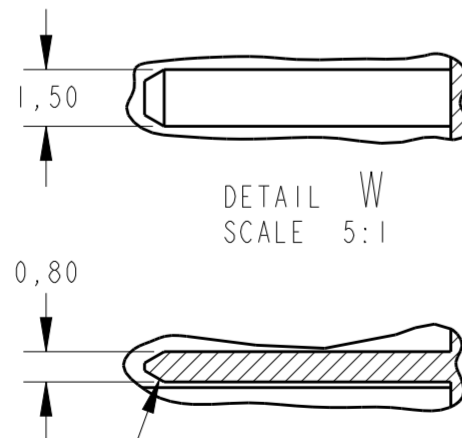

DETAIL W  
 SCALE 5:1

A PONTA DOS TABS DEVE SER LIVRE DE DEFEITOS  
 TABS ENDS MUST BE FREE OF DEFECTS

SECTION B-B

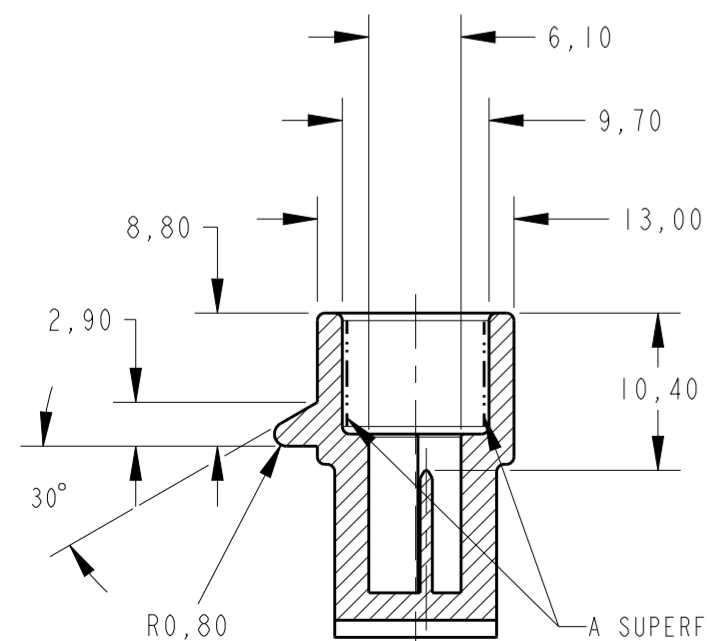

SECTION B-B

A SUPERFÍCIE DE SELAGEM DEVE SER LIVRE DE DEFEITOS  
 SEALING SURFACE MUST BE FREE OF DEFECTS

TOLERÂNCIAS NÃO ESPECIFICADAS=±0,1  
 NOT SPECIFIED TOLERANCES=±0.1

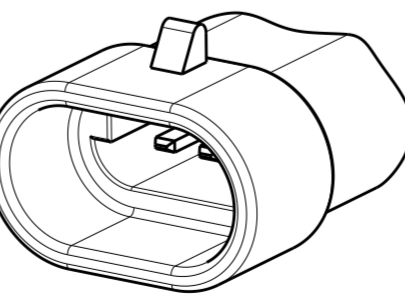

PERSPECTIVE VIEW  
 SCALE 2:1

THIS DRAWING IS A CONTROLLED DOCUMENT.

DIMENSIONS: mm	TOLERANCES UNLESS OTHERWISE SPECIFIED: 0 PLC ± 1 PLC ±0.3 2 PLC ± 3 PLC ± 4 PLC ± ANGLES ±1° FINISH	DWN A. PERUSSI 05DEC2005 CHK P. L. FARIA 05DEC2005 APVD J. W. PRADO 05DEC2005 PRODUCT SPEC - / - APPLICATION SPEC - / - WEIGHT - / -	NAME HOUSING ASSY, 3 POSN. MULTI-LOCK RECEP. SIZE A2 CAGE CODE - DRAWING NO. C-444043 RESTRICTED TO -
-------------------	--	---	---

Customer Drawing SCALE 4:1 SHEET OF REV K